



EDO Tip Seal Replacement

INSTRUCTION MANUAL

Copyright notice

©Edwards Limited 2021. All rights reserved.

Associated publications

Publication title	Publication number
Vacuum pump and vacuum system safety	P40040100
EDO Scroll pump Instruction manual	A50871880

Trademark credit

Edwards and the Edwards logo are trademarks of Edwards Limited, Innovation Drive, Burgess Hill, West Sussex RH15 9TW.

Disclaimer

The content of this manual may change from time to time without notice. We accept no liability for any errors that may appear in this manual nor do we make any expressed or implied warranties regarding the content. As far as practical we have ensured that the products have been designed and constructed to be safe and without risks when properly installed and used in accordance with their operating instructions.

We accept no liability for loss of profit, loss of market or any other indirect or consequential loss whatsoever.

Product warranty and limit of liability are dealt with in our standard terms and conditions of sale or negotiated contract under which this document is supplied.

You must use this product as described in this manual. Read the manual before you install, operate, or maintain the product.

Contents

1. Safety and compliance.	5
1.1 Definition of Warnings and Cautions.	5
1.2 Trained personnel	5
1.3 Safety symbols.	6
2. Important safety information.	7
3. Description.	8
3.1 Tip seal replacement on EDO65 pump.	8
4. Service.	13
4.1 Return the equipment or components for service	13

List of Figures

Figure 1: Orbit scroll - Fitting the tip seals.	10
Figure 2: Fixed scroll - Fitting the tip seals.	11
Figure 3: Replacing the tip seals on EDO65 pump.	12

1. Safety and compliance

1.1 Definition of Warnings and Cautions

NOTICE:



For safe operation from the start, read these instructions carefully before you install or commission the equipment and keep them safe for future use.

Read all the safety instructions in this section and the rest of this manual carefully and make sure that you obey these instructions. The equipment must only be operated and maintained by trained personnel in the proper condition and as described in this instruction manual.

Obey local and state requirements and regulations. If you have any questions about safety, operation or maintenance of the device, please contact our nearest subsidiary.

Important safety information is highlighted as warning and caution instructions. Obey these instructions.



WARNING:

If you do not obey a warning, there is a risk of injury or death. Different symbols are used according to the type of hazard.



CAUTION:

If you do not obey a caution, there is a risk of minor injury, damage to equipment, related equipment or process.



NOTICE:

Information about properties or instructions for an action which, if ignored, will cause damage to the equipment.

We reserve the right to change the design and the stated data. The illustrations are not binding.

Keep the instructions for future use.

1.2 Trained personnel









For the operation of this equipment “trained personnel” are:

- skilled workers with knowledge in the fields of mechanics, electrical engineering, pollution abatement and vacuum technology and
- personnel specially trained for the operation of vacuum pumps

1.3 Safety symbols

The safety symbols on the products show the areas where care and attention is necessary.

The safety symbols that follow are used on the product or in the product documentation.

	Warning/Caution An appropriate safety instruction must be followed or caution to a potential hazard exists.
	Warning - Dangerous voltage Identifies possible hazards from dangerous voltages.
	Warning - Heavy object Identifies a possible hazard from a heavy object.
	Warning - Hot surfaces Identifies a potential hazard from a hot surface.
	Warning - Read the manual
	Warning - Use protective equipment Use appropriate protective equipment for the task.
	WEEE symbol The equipment must be discarded carefully. Obey local and national regulations for disposal of this equipment.
	Warning - Protective earth (ground) Earth point for electrical equipment.
	Warning - Do not step Personnel must not step onto the marked area.

2. Important safety information

- Vacuum pumps are potentially dangerous if incorrectly used, repaired or maintained. You must approach the repair or maintenance with caution.
- Any incorrectly fitted spare parts will damage your pump and can be potentially dangerous.
- Never allow unqualified personnel to attempt to remove or replace any part of the pump.
- If you have any doubts about the servicing procedures or the products capabilities, contact us.
- Always follow the service schedules unless adverse conditions leads to more frequent servicing.
- Report any defect before an accident or consequential damage can occur.
- Observe local and national regulations, norms and guidelines.
- Never allow anyone to remove large or heavy components without adequate lifting equipment.
- Before you start the maintenance work, make sure that the pump is switched off and isolated from the mains.
- The pump may have been exposed to processes which use hazardous substances or produces by-products which are dangerous to human health and safety, for example, chemically active, biologically active or radioactive substances.
- Before working on a pump, make sure that the correct personal protective equipment is available and being used. Always wear safety goggles. Wear a breather mask with positive air pressure and take other precautions if you believe the pump may be contaminated with hazardous substances and dusts.
- When you apply sealants and lubricants, prevent contact with the skin by wearing suitable gloves.
- Seals may contain fluoroelastomer, which when properly handled is not dangerous, but which may produce a toxic and corrosive residue (hydrogen fluoride or hydrofluoric acid) in the event of excessive heat or fire depending on the circumstances of degradation and other materials involved.
- On completion of maintenance, check that the pump functions correctly. All guards and protection devices must be fitted and working correctly. The pump must be electrically safe.
- If the pump is used for handling hazardous substances check the pump for leak-tightness before use.
- Dispose of waste oil and any process by-products in accordance with local and national safety and environmental requirements. It is usually illegal to dispose of waste oil into drains or water courses or to bury it.

3. Description

3.1 Tip seal replacement on EDO65 pump



WARNING: NON-INTENDED USAGE

Risk of explosion. The pump is not intended to be used in an explosive atmosphere and must be used in accordance with the Instruction manual (Publication Number A50871880).



CAUTION: LOOSE ASSEMBLY

Risk of damage to equipment. Make sure that the Orbit scroll assembly is not dropped when you remove the fixings.

To replace the tip seal, do the steps that follows:

1. Switch off the pump and isolate the electrical supply. Allow the pump to cool.
2. Vent the pump with the gas ballast to position ON (open in counter-clockwise direction).

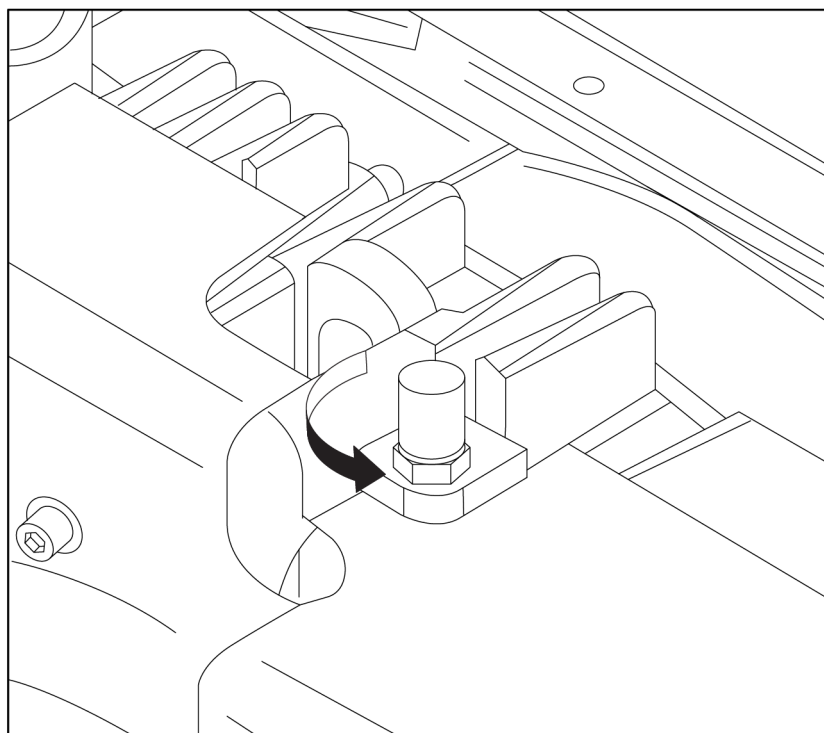

3. Refer to [Figure: Replacing the tip seals on EDO65 pump](#). Remove the five screws which secure the front cover.
4. Remove the Inlet filter assembly.
5. Remove the four screws which secure the Orbit scroll cover.
6. Remove the one screw which secures the Balance weight main.
7. Remove the eight screws which secures the Anti-rotation assembly.
8. Carefully separate the Orbit scroll assembly from the housing assembly.

9. Put the Orbit scroll assembly on a flat surface so that the scroll is facing upwards.
10. Starting from one end, remove the tip seals from the Orbit scroll.
11. Starting from one end, remove the tip seals from the Fixed scroll.
12. Dispose of all used items that have been removed.
13. Use a clean dry lint-free cloth and remove all dust and process debris from the scroll forms and grooves.
14. Take a new tip seal and fit it using the following technique in both the orbiting scroll and fixed scroll:
 - A. Start at the centre of the scroll form and insert the tip seal into the tip seal channel. Make sure that each tip seal starts as close as possible at the start of the scroll channel with the polished side up. Refer to [Figure: Orbit scroll - Fitting the tip seals](#) and [Figure: Fixed scroll - Fitting the tip seals](#).
 - B. Continue to push the tip seal into the tip seal channel while working your way around the channel profile until you have reached the end. Make sure that the tip seal is pressed squarely and fully home at each pinch point, these are located closer to the centre of the scroll.
 - C. Cut short the tip seal at the end of the scroll channel. There should be a gap at least 3 -6 mm between the end of the channel and the tip seal, this is to allow for expansion. Refer to Section A in [Figure: Orbit scroll - Fitting the tip seals](#) and [Figure: Fixed scroll - Fitting the tip seals](#).
 - D. Remove any tip seal debris which may have been produced while inserting the new tip seals.

 **Note:**

The EDO pump has multiple tip seal starts in both the Orbiting and Fixed scrolls.

Make sure that the tip seal is pushed fully home with finger pressure particularly at the pinch-points, before re-assembly.

15. Refer to [Figure: Replacing the tip seals on EDO65 pump](#). Make sure that the shim (2.3 mm thick) is still attached on the motor shaft.
16. Make sure that the shaft key is pushed to the end of keyway.
17. Make sure that the tip seals do not fall out from groove.
18. Attach the Orbit scroll assembly onto the motor shaft by hand using even pressure. The right gap between the scrolls should be approximately 0.2 mm. If the gap is significantly higher than required value, repeat the steps 15-17.

 **Note:**

The Orbit scroll assembly must be fitted evenly while tightening each screw. Do not start by assembling one side first

19. Assemble the Balance weight main by tightening the one screw to the motor shaft.
20. Assemble the Anti-rotation assembly and tighten the eight fastening screws progressively and evenly onto the Orbit scroll assembly.
21. Assemble the Orbit scroll cover and tighten the four fixing screws evenly onto the Orbit scroll assembly. Always tighten the screws in a cross-bolt tightening pattern.
22. Assemble the Inlet filter assembly into the housing assembly.

23. Assemble the Front cover and tighten the five fixing screws progressively and evenly onto the housing assembly with a tightening torque of 8 Nm. Always tighten the screws in a cross-bolt tightening pattern.
24. Install the pump in accordance with Installation of the EDO Scroll pump manual (Publication number A50871880).
25. When you operate the pump after a tip seal change, make sure that the cooling fan rotate in the correct direction. If not refer to EDO Scroll pump manual and check the direction of pump rotation.

 **Note:**

The pump tip seals may take a few hours to bed-in before full performance is restored.

Figure 1 Orbit scroll - Fitting the tip seals

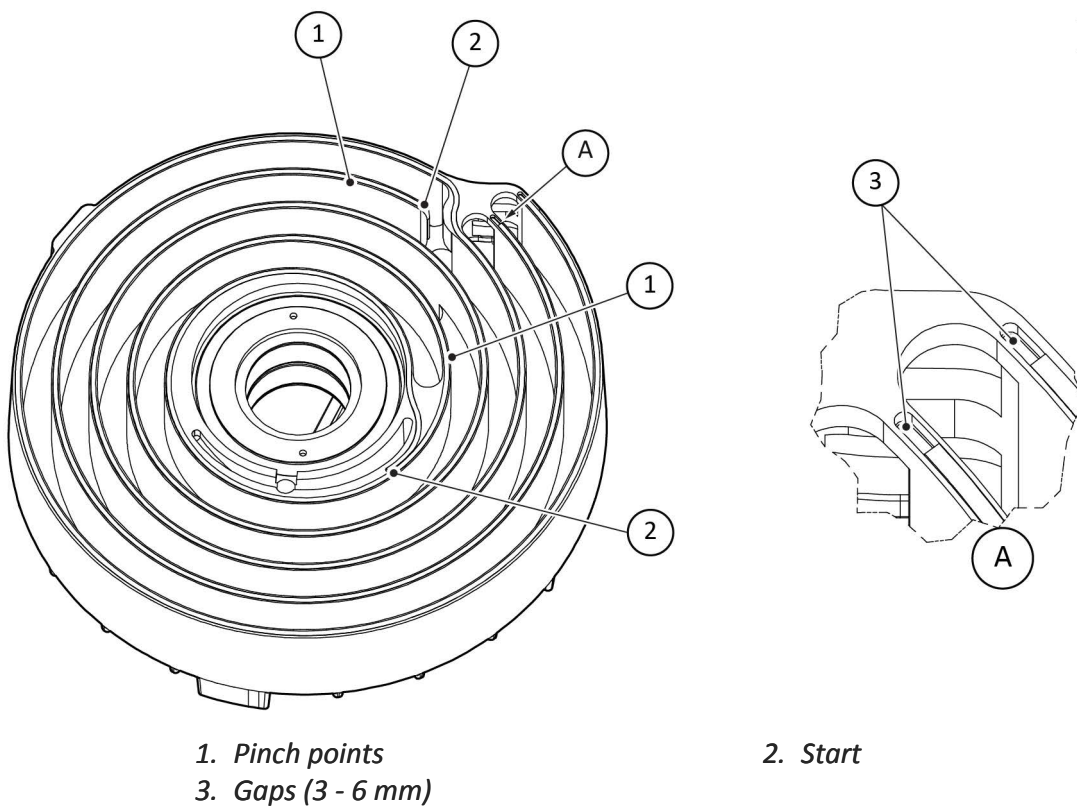
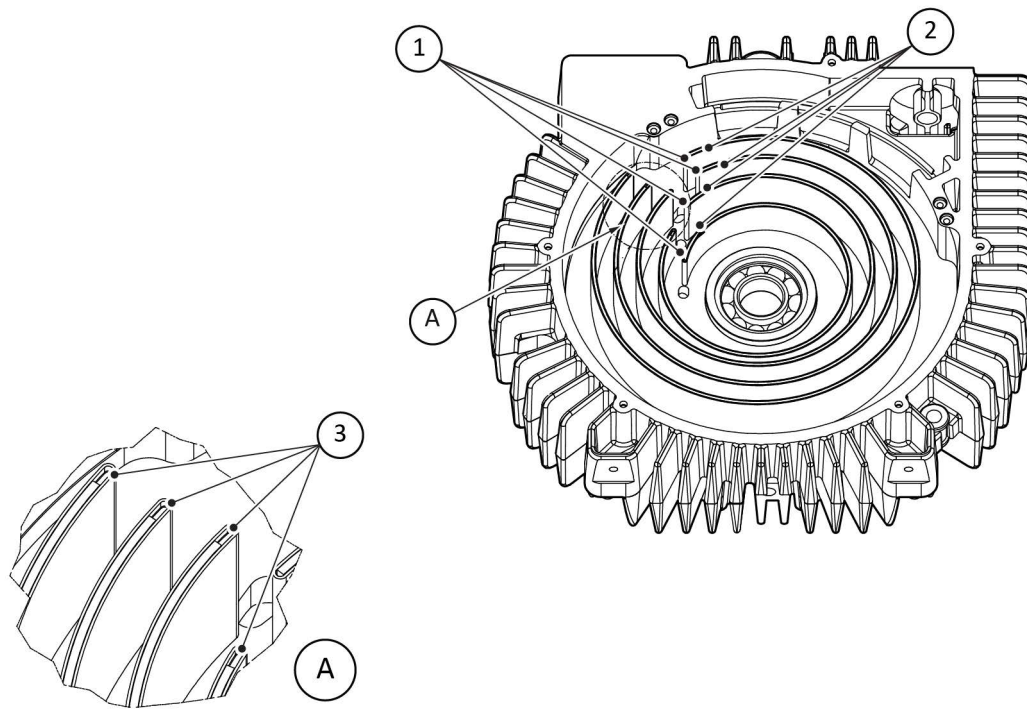

Figure 2 Fixed scroll - Fitting the tip seals



- 1. Start
- 3. Gaps (3 - 6 mm)

- 2. Pinch points

Figure 3 Replacing the tip seals on EDO65 pump

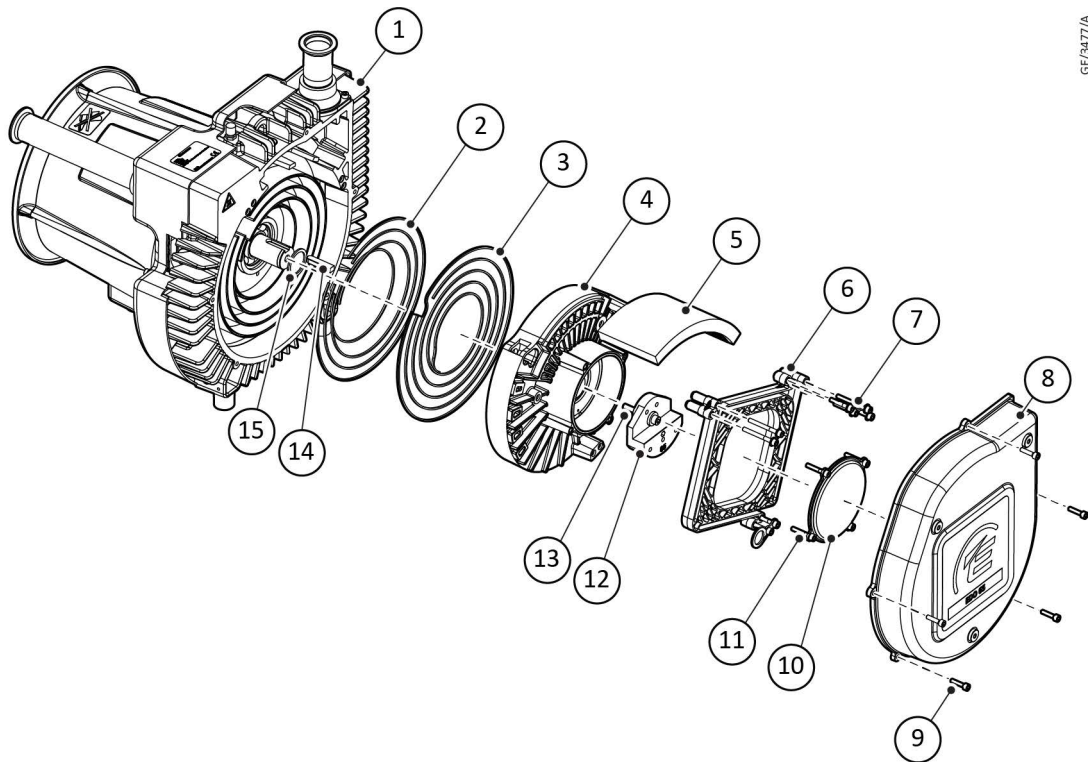

GE/B4771/A

- | | |
|-------------------------------|---------------------------------|
| 1. Fixed scroll assembly | 2. Tip seal - fixed scroll |
| 3. Tip seal - orbit scroll | 4. Orbit scroll assembly |
| 5. Inlet filter assembly | 6. Anti-rotation assembly |
| 7. Screw M6 on frog x8 | 8. Front cover assembly |
| 9. Screw M6 on front cover x5 | 10. Orbit scroll cover assembly |
| 11. Screw M5 on OS cover x4 | 12. Balance weight main |
| 13. Screw M8 | 14. Shaft key |
| 15. Shim 2.3 mm | |

4. Service

4.1 Return the equipment or components for service

Before you send your equipment to us for service or for any other reason, you must send us a completed Declaration of Contamination of Vacuum Equipment and Components – Form HS2. The HS2 form tells us if any substances found in the equipment are hazardous, which is important for the safety of our employees and all other people involved in the service of your equipment. The hazard information also lets us select the correct procedures to service your equipment.

We provide instructions for completing the form in the Declaration of Contamination of Vacuum equipment and Components – Procedure HS1.

If you are returning a vacuum pump, note the following:

- If a pump is configured to suit the application, make a record of the configuration before returning the pump. All replacement pumps will be supplied with default factory settings.
- Do not return a pump with accessories fitted. Remove all accessories and retain them for future use.
- The instruction in the returns procedure to drain all fluids does not apply to the lubricant in pump oil reservoirs.

Download the latest documents from edwardsvacuum.com/HSForms/, follow the procedure in HS1, fill in the electronic HS2 form, print it, sign it, and return the signed copy to us.

**NOTICE:**

If we do not receive a completed HS2 form, your equipment cannot be serviced.

