

nXRi HIGH PERFORMANCE COMPACT DRY VACUUM PUMP

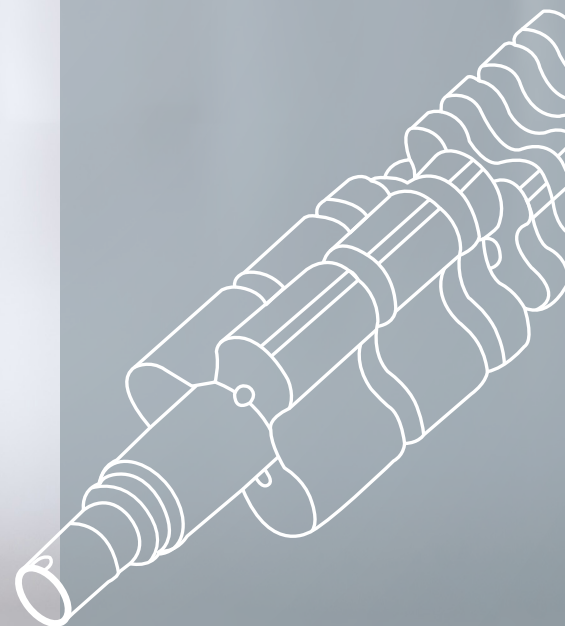



EDWARDS THE PARTNER OF CHOICE

Edwards is a world leader in the design, technology and manufacture of vacuum pumps with over 100 years of history and more than 80 years of manufacturing experience.

We believe in delivering results that bring value to our customers by using our breadth of industry experience to identify and apply solutions to your problems. Using the most innovative and up-to-date modeling techniques, we can optimise the pumping configuration for customers to provide a system design giving the maximum performance in the most reliable and cost-effective way.

nXRi HIGH PERFORMANCE COMPACT DRY VACUUM PUMP

When performance matters

Edwards has revolutionised the vacuum pump market with the new nXRi high performance, compact dry pump. It delivers unrivalled pumping speeds in the most compact package, with pumping speeds of 30 to 120 m³h⁻¹. The nXRi's lower input power and zero maintenance create real performance improvements and cost benefits across a range of applications.

Analytical Instrument OEMs benefit from the ease of integration into most vacuum systems for a ready to go vacuum solution, perfect for mass spectrometry, electron microscopy and leak detection.

R&D and Industrial customers will enjoy the design flexibility, oil-free and low maintenance features.

- **Energy efficiency. Reduce your costs!**
- **Unrivalled performance. When you need it!**
- **Zero contamination. Experience the difference!**
- **Compact footprint. Optimise your space!**

APPLICATIONS

Analytical instruments

- Electron microscopy
- Mass spectrometry
- RGA

Scientific research and development

- UHV
- High energy physics
- General use

Industrial

- Drying
- Plasma cleaning
- Cryo regeneration



COMPACT FOOTPRINT

Optimise your space!

Designed with size in mind, the compact footprint and height allow the nXRi dry pump to fit easily under a benchtop saving valuable space in your laboratory; and at under 30 kg offers a highly portable vacuum pump for changing work flows and environments.



UNRIVALLED PERFORMANCE

When you need it!

When performance matters look no further than the nXRi dry pump, with pumping speed performance of 30 to 120 m³h⁻¹ from our most compact footprint. It delivers six times more pumping speed than similar sized dry pumps, and with low ultimate and high reliability you are assured a consistent and stable vacuum for years to come.



ZERO CONTAMINATION

Experience the difference!

Clean processes and clean results are guaranteed with the nXRi compact dry pump, fully oil-free, and dust-free within the vacuum chamber. Being free of oil and smells guarantees a more pleasant working environment.

CONTROL WITH EASE

Equipped with a single-phase pump controller covering a wide voltage range of 100-127V/200-240V, the pump achieves consistent performance anywhere in the world. The pump can be controlled easily with the convenient dashboard or remotely via parallel or serial control. The integrated USB port allows monitoring with our free nST2 software. The additional accessory port allows automatic control of valves as our VIV Vacuum Isolation Valve for full power loss protection.



TECHNICAL SPECIFICATION

Peak pumping speed

nXR30i	30 m ³ h ⁻¹
nXR40i	40 m ³ h ⁻¹
nXR60i	60 m ³ h ⁻¹
nXR90i	90 m ³ h ⁻¹
nXR120i	120 m ³ h ⁻¹

Ultimate vacuum (total pressure)	0.03 mbar (0.022 Torr)
-----------------------------------------	------------------------

Inlet flange	
nXR30/40i	NW25
nXR60/90/120i	NW40

Outlet flange	
All variants	NW25

Maximum permitted outlet pressure	
nXR30/40/60/90/120i	0.2 bar gauge

Maximum continuous inlet pressure	
nXR30-90i	1013 mbar
nXR120i	20 mbar

Operating temperature range	+5 to +40°C (+41 to +104°F)
------------------------------------	-----------------------------

Nominal rotational speed	15000 rpm
---------------------------------	-----------

Voltage input	100-127/200-240 V (+/-10%), switchable
----------------------	----------------------------------------

Mains frequency	50/60 Hz
------------------------	----------

Power connector 1-ph	IEC EN60320 C19
-----------------------------	-----------------

Power at ultimate	450 W
--------------------------	-------

Leak tightness	< 1x10 ⁻⁶ mbar ls ⁻¹
-----------------------	--------------------------------------------

Weight	
nXR30/40i	27 kg (60 lbs)
nXR60/90/120i	29 kg (64 lbs)

Noise at ultimate vacuum	55 dB(A)
---------------------------------	----------

Vibration at inlet flange	< 2.0 mm/s
----------------------------------	------------



DIMENSIONS

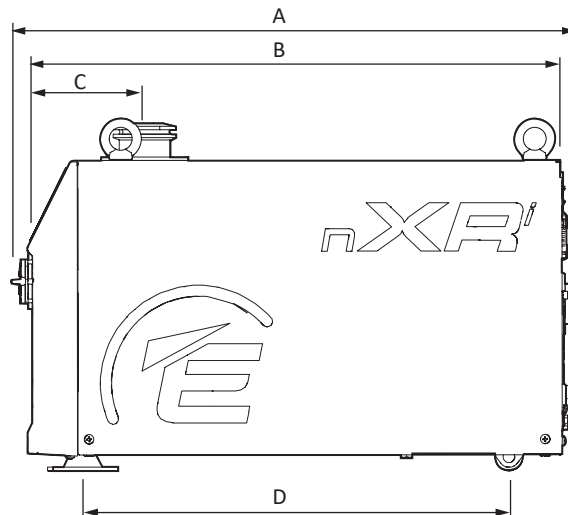
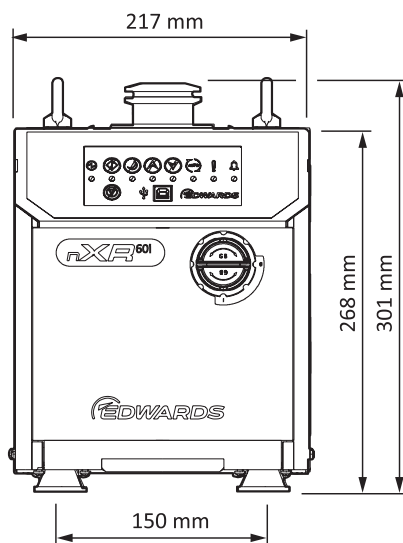

	nXR30/40i	nXR60/90/120i
A	478 mm	494 mm
B	443 mm	461 mm
C	103 mm	107 mm
D	339 mm	370 mm

PUMPING PERFORMANCE

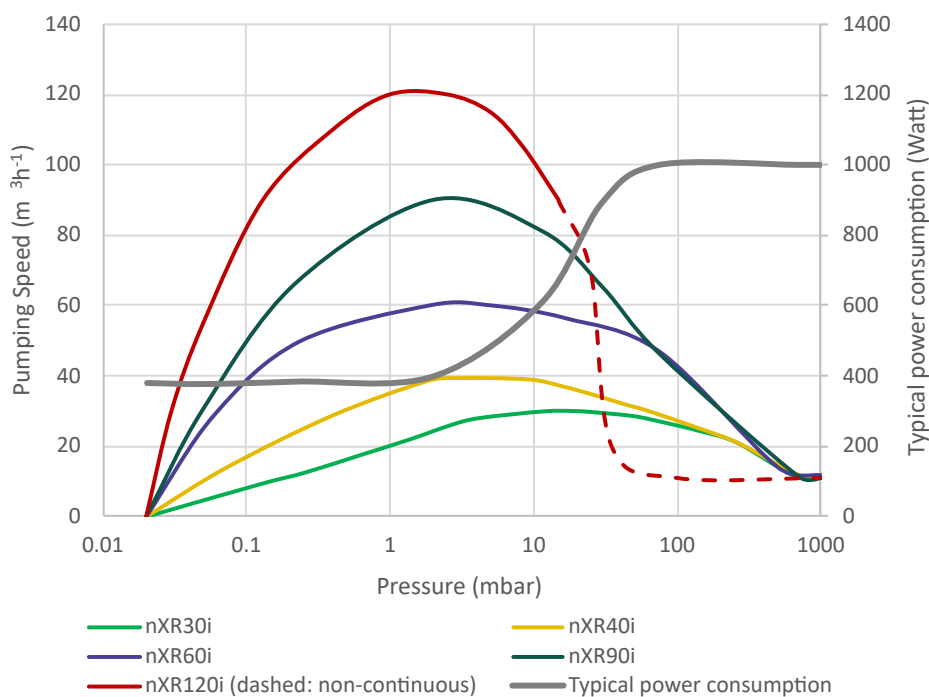

ORDERING INFORMATION

Product description

Order number

nXR30i NW25 Multi Stage Roots Dry Pump 100-127/200-240V 50/60 Hz

A90301983

nXR40i NW25 Multi Stage Roots Dry Pump 100-127/200-240V 50/60 Hz

A90401983

nXR60i NW40 Multi Stage Roots Dry Pump 100-127/200-240 V, 50/60 Hz

A90502983

nXR90i NW40 Multi Stage Roots Dry Pump 100-127/200-240 V, 50/60 Hz

A90602983

nXR120i NW40 Multi Stage Roots Dry Pump 100-127/200-240V 50/60 Hz

A90702983

ACCESSORIES

Product description

Order number

2m electrical supply cable, NEMA 5-15P, North America/Japan (100-120 V)

A50507003

2m electrical supply cable, NEMA 6-15P, North America (200-240 V)

A50507006

2m electrical supply cable, UK, three pin plug

A50505003

2m electrical supply cable, Europe

A50506003

2m electrical supply cable, China

A50509003

Gas ballast blank plug

A73501806

Gas ballast adaptor for inert gas (1/4" quick connect)

A73501811

Floor/cart mounting kit

A90590000



Publication Number: 3601 0591 01

© Edwards Limited 2021. All rights reserved. Edwards and the Edwards logo are trademarks of Edwards Limited

Whilst we make every effort to ensure that we accurately describe our products and services, we give no guarantee as to the accuracy or completeness of any information provided in this brochure.

Edwards Ltd, registered in England and Wales

No. 6124750, registered office: Innovation Drive, Burgess Hill, West Sussex, RH15 9TW, UK.